

WWW.FITTINGSPLUS.COM

FITTINGS PLUS

CASTINGS

CATALOG 2023



AMID

INDEX

About Us	04
American Company	05
Find us	06
Aluminum Post Caps	08
Aluminum Finials	010
Aluminum Shoes/Bases	011
Aluminum Cover Shoes	012
Aluminum Rosettes	013
Aluminum Collars	014
Aluminum Weld Tabs	015
Aluminum Rings	016
Aluminum Dixie Rail	017
Aluminum End Caps	018
Aluminum Wall Mounts	019
Aluminum Plants & Animals	021
Aluminum Decorative Castings	023
Aluminum Forge Items	024
Grip Rail Accessories	026

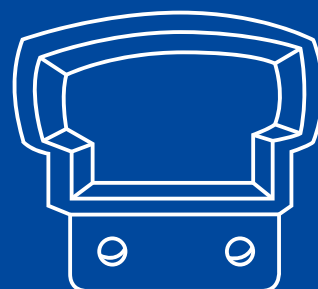

About Us

★ ★ ★ ★ ★
TOP
QUALITY

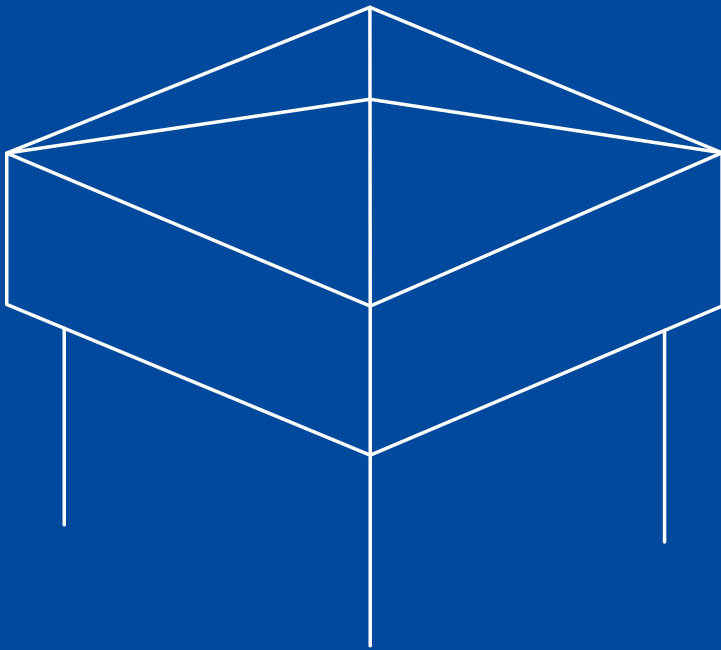

AMD SUPPLY, LLC has been in business for over 15 years and is quickly growing into one of the largest distributors of aluminum and fencing products in Florida.

AMD Supply serves the state from Pensacola south to Naples on the west coast, from Orlando east and south to Miami - Key West, with quality aluminum and fence products such as:

- **Fence and Gate Hardware**
- **Aluminum Castings**
- **Plastic Casting**
- **Steel Accessories**
- **Screen Door Accessories**
- **And More**

AMERICAN Company

We provide a one-stop-shop solution to our customers.

NO MINIMUM ORDER!

AMD Supply has built a reputation for providing the best service in the industry.

Top Rated Aluminum Distributor

- Fully bilingual sales team (English/Spanish)
- Over 150 years of combined experience in the aluminum and fencing industry.
- Faster response to your inquiries than our competitors.
- World-class sales and inventory management system.
- Check inventory, quote prices and ship to anywhere in the world.
- Packaged and shipped ASAP.

Find Us

Port St., Lucie, FL

630 NW Peacock Blvd, Suite 10
34986

☎ 772 - 212 - 9180

✉ salespsl@amdaluminum.com

Miramar, FL

15701 SW 29th St, Suite 100
33027

☎ 786 - 621 - 6706

✉ sales@amdaluminum.com

Deerfield Beach, FL

604 Hillsboro Technology Dr.
33441

☎ 954 - 530 - 9385

✉ salesfp@amdaluminum.com

Boynton Beach, FL

3050 SW 14th Pl
33426

☎ 754 - 800 - 4098

✉ salesbb@amdaluminum.com

Pensacola, FL

2001 W. Government St.
32502

☎ 850 - 432 - 2485

✉ salespen@amdaluminum.com

Pensacola, FL

2370 N. Palafox Street
32501

☎ 850 - 446 - 0636

✉ bjessee@amdaluminum.com

Fort Myers, FL

9373 Laredo Ave Ste 170
33905

☎ 239 - 225 - 9041

✉ salesft@amdaluminum.com



C A S T I N G S
C A T A L O G 2 0 2 3

Revision **001**
26-05-2023



ALUMINUM POST CAPS

Find post caps to fit nearly every type of fence and railing system

FLAT DIE CAST

AL11.006
1 1/4"



WEIGHT: 0.04 LB

FLAT DIE CAST

AL11.015
1 1/2"



WEIGHT: 0.05 LB

PYRAMID SAND CAST

AL11.022
2"



WEIGHT: 0.15 LB

PYRAMID DIE CAST

AL11.023
2"



WEIGHT: 0.25 LB

PYRAMID DIE CAST

AL11.023.BK
2"



BLACK
WEIGHT: 0.25 LB

PYRAMID DIE CAST

AL11.023.BZ
2"



BRONZE
WEIGHT: 0.25 LB

PYRAMID DIE CAST

AL11.023.WH
2"



WHITE
WEIGHT: 0.25 LB

BALL DIE CAST

AL11.027
2"



H 3 3/4"
DIA 2"
WEIGHT: 0.55 LB

FLAT DIE CAST

AL11.030
2"



MILL PRESS-FIT
WEIGHT: 0.10 LB

FLAT DIE CAST

AL11.030.BK
2"



BLACK PRESS-FIT
WEIGHT: 0.10 LB

FLAT DIE CAST

AL11.030.WH
2"



WHITE PRESS-FIT
WEIGHT: 0.10 LB

FLAT DIE CAST

AL11.030.BZ
2"



BRONZE PRESS-FIT
WEIGHT: 0.10 LB

BALL DIE CAST

AL11.049
2 1/2"



H 3 3/4"
DIA 1 7/8"
WEIGHT: 0.60 LB

FLAT DIE CAST

AL11.050
2 1/2"



WEIGHT: 0.15 LB

BALL DIE CAST

AL11.059
3"



H 4 1/2"
DIA 2 1/4"
WEIGHT: 0.70 LB

PYRAMID DIE CAST

AL11.057
3"



WEIGHT: 0.20 LB

FLAT DIE CAST

AL11.061
3"



WEIGHT: 0.20 LB

PYRAMID DIE CAST

AL11.067
4"



WEIGHT: 0.35 LB

BALL DIE CAST

AL11.065
4"



H 5"
DIA 2 1/2"
WEIGHT: 1.10 LB

BALL SAND CAST

AL11.068
4"



H 5 1/4"
DIA 2 1/2"
WEIGHT: 1.40 LB

Find post caps to fit nearly every type
of fence and railing system

ALUMINUM POST CAPS



FLAT DIE CAST

AL11.070

4"



WEIGHT: 0.30 LB

PYRAMID SAND CAST

AL11.076

5"



WEIGHT: 1.00 LB

PYRAMID DIE CAST

AL11.079

6"



WEIGHT: 0.80 LB

FLAT DIE CAST

AL11.080

6"



WEIGHT: 0.80 LB

BALL SAND CAST

AL11.081

6"



H 8 1/2"
DIA 5"

WEIGHT: 5.20 LB

PYRAMID SAND CAST

AL11.086

8"



WEIGHT: 4.00 LB

BALL SAND CAST

AL11.110

3"



FOR ROUND
POST

WEIGHT: 1.00 LB

BALL SAND CAST

AL11.120

4"



FOR ROUND
POST

WEIGHT: 1.40 LB



ALUMINUM FINIALS

Our finials can be used as added ornamental decoration or replacement parts for ornamental fences

PLUG IN DIE CAST

AL12.011

3/4"

H 3 7/8"
W 1 3/8"

WEIGHT: 0.20 LB



SLIP ON DIE CAST

AL12.012

3/4"

H 4 1/4"
W 1 1/4"
BASE: 1 1/8"

WEIGHT: 0.10 LB



SLIP ON DIE CAST

AL12.022

3/4"

H 4 1/4"
W 3 1/4"
BASE: 1 1/8"

WEIGHT: 0.25 LB



PLUG IN DIE CAST

AL12.025

3/4"

H 4 3/4"
W 2 5/8"

WEIGHT: 0.20 LB



SLIP ON DIE CAST

AL12.032

3/4"

H 4 1/4"
W 2 1/2"
BASE: 1 1/8"

WEIGHT: 0.10 LB



PLUG IN DIE CAST

AL12.103

1"

H 4 1/4"
W 1 3/8"

WEIGHT: 0.20 LB



SLIP IN DIE CAST

AL12.107

1"

H 6"
W 2 3/4"
BASE: 1 3/8"

WEIGHT: 0.20 LB



PLUG IN DIE CAST

AL12.108

1"

H 4 1/2"
W 2 3/4"

WEIGHT: 0.30 LB



Add an elegant finish to your porch, deck and balcony with our shoes and flanges in aluminum

ALUMINUM SHOES/BASES

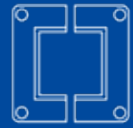

<p>DIE CAST DOUBLE EAR</p> <p>AL13.006 1"</p> <p>BASE 2 5/8" X 1 3/8" HEIGHT 1"</p>  <p>WEIGHT: 0.10 LB</p>	<p>DIE CAST HD FLANGED</p> <p>AL13.010 1.4" X 1.8"</p> <p>HR-4A HEIGHT 1 3/4"</p>  <p>WEIGHT: 0.31 LB</p>	<p>DIE CAST HD FLANGED</p> <p>AL13.017 1 1/2"</p> <p>BASE 3 3/4" SQ HEIGHT 1 3/4"</p>  <p>WEIGHT: 0.50 LB</p>	<p>SAND CAST</p> <p>AL13.022 2"</p> <p>BASE 4" SQ HEIGHT 1 1/2"</p>  <p>WEIGHT: 0.45 LB</p>
<p>DIE CAST HD FLANGED</p> <p>AL13.024 2"</p> <p>BASE 4 3/8" SQ HEIGHT 1 3/4"</p>  <p>WEIGHT: 0.82 LB</p>	<p>DIE CAST HD FLANGED</p> <p>AL13.024.BK 2"</p> <p>BLACK</p> <p>BASE 4 3/8" SQ HEIGHT 1 3/4"</p>  <p>WEIGHT: 0.82 LB</p>	<p>DIE CAST HD FLANGED</p> <p>AL13.024.BZ 2"</p> <p>BRONZE</p> <p>BASE 4 3/8" SQ HEIGHT 1 3/4"</p>  <p>WEIGHT: 0.82 LB</p>	<p>DIE CAST HD FLANGED</p> <p>AL13.024.WH 2" WHITE</p> <p>BASE 4 3/8" SQ HEIGHT 1 3/4"</p>  <p>WEIGHT: 0.82 LB</p>
<p>DIE CAST</p> <p>AL13.032 2" BALCONY SHOE</p> <p>BASE 4 1/8" X 3 1/2" HEIGHT 1 3/4"</p>  <p>WEIGHT: 0.50 LB</p>	<p>DIE CAST HD FLANGED</p> <p>AL13.040 2 1/2"</p> <p>BASE 4 7/8" SQ HEIGHT 1 3/4"</p>  <p>WEIGHT: 1.20 LB</p>	<p>DIE CAST</p> <p>AL13.043 3"</p> <p>BASE 5" SQ HEIGHT 2"</p>  <p>WEIGHT: 0.60 LB</p>	<p>DIE CAST HD FLANGED</p> <p>AL13.045 3"</p> <p>BASE 5 3/8" SQ HEIGHT 1 3/4"</p>  <p>WEIGHT: 2.00 LB</p>
<p>DIE CAST</p> <p>AL13.046 4"</p> <p>BASE 6 1/2" SQ HEIGHT 1 7/8"</p>  <p>WEIGHT: 0.80 LB</p>	<p>INTERNAL BASE PLATE</p> <p>AL13.047 3X3"</p>  <p>WEIGHT: 0.23 LB</p>	<p>INTERNAL BASE PLATE</p> <p>AL13.048 4X4"</p>  <p>WEIGHT: 0.32 LB</p>	<p>BASE PLATE</p> <p>AL13.100 3"</p> <p>3" SQ WITH HOLES</p>  <p>WEIGHT: 0.18 LB</p>
<p>BASE PLATE</p> <p>AL13.101 4"</p> <p>4" SQ WITH HOLES</p>  <p>WEIGHT: 0.33 LB</p>	<p>BASE PLATE</p> <p>AL13.102 5"</p> <p>5" SQ WITH HOLES</p>  <p>WEIGHT: 0.5 LB</p>		

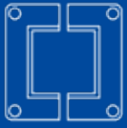

ALUMINUM COVER SHOES

Hide your base plates and core drill holes with our assortment of cover shoes.

DIE CAST

AL13.034
2"

MILL



BASE 4 3/8" X 3 3/4"
HEIGHT 1 3/8"

WEIGHT: 0.35 LB

DIE CAST

AL13.034.BK
2"

BLACK



BASE 4 3/8" X 3 3/4"
HEIGHT 1 3/8"

WEIGHT: 0.35 LB

DIE CAST

AL13.034.BZ
2"

BRONZE



BASE 4 3/8" X 3 3/4"
HEIGHT 1 3/8"

WEIGHT: 0.35 LB

DIE CAST

AL13.034.WH
2"

WHITE



BASE 4 3/8" X 3 3/4"
HEIGHT 1 3/8"

WEIGHT: 0.35 LB

DIE CAST

AL13.035
2"



BASE 4 3/4" SQ
HEIGHT 7/8"

WEIGHT: 0.25 LB

STAINLESS
COUNTERSUNK
SCREWS
INCLUDED

DIE CAST

AL13.037
2"

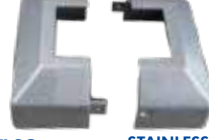

BASE 4 3/4" SQ
HEIGHT 1 7/8"

WEIGHT: 0.40 LB

STAINLESS
COUNTERSUNK
SCREWS
INCLUDED

DIE CAST

AL13.041
2 1/2"



BASE 5" SQ
HEIGHT 7/8"

WEIGHT: 0.30 LB

STAINLESS
COUNTERSUNK
SCREWS
INCLUDED

DIE CAST

AL13.042
3"



BASE 5 1/2" SQ
HEIGHT 1 3/4"

WEIGHT: 0.4 LB

Aluminum rosettes can set a striking tone in any space. Available in many shapes, sizes and designs

ALUMINUM ROSETTES



PINWHEEL

AL14.071



SF
DIA 3"

WEIGHT: 0.05 LB

SEA SHELL

AL14.076



SF
H 3 3/4"
5/8" THICK

WEIGHT: 0.60 LB

8 PETAL FLOWER

AL14.080



SF
H 4"
W 30"

WEIGHT: 1.75 LB

DISC

AL14.082



3/16" X 4"

WEIGHT: 0.23 LB

FLEUR - DE - LIS

AL14.085



SF
H 4 1/2"
W 3 1/2"

WEIGHT: 0.15 LB

FLEUR - DE - LIS

AL14.094



FB
H 9"
W 6 7/8"

WEIGHT: 1.20 LB



ALUMINUM COLLARS

Ideal for Decorating Fence and
Railing Pickets

DIE CAST

AL14.005

5/8"
SQUARE



H 1 3/4"
W 1 5/8"

WEIGHT: 0.15 LB

SAND CAST

AL14.006

3/4"
SQUARE



H 1 3/4"
DIA 2"

WEIGHT: 0.30 LB

DIE CAST

AL14.007

3/4"
SQUARE



H 2 1/8"
W 1 7/8"

WEIGHT: 0.20 LB

DIE CAST

AL14.008

3/4" HEAVY
COLLAR



H 1 7/8"
W 2 1/8"

WEIGHT: 0.23 LB

Aluminum weld tabs for attaching your finished parts to walls and columns.

ALUMINUM WELD TABS



WELD TAB

AL14.215



1 5/8" X 1"

WEIGHT: 0.22 LB

WELD TAB

AL14.216



2 1/4" X 1"

WEIGHT: 0.34 LB

WELD TAB

AL14.217



2 5/8" X 2"
FLEUR-DE-LIS

WEIGHT: 0.41 LB

WELD TAB

AL14.218



3 1/2" X 2"
FLEUR-DE-LIS

WEIGHT: 0.54 LB

WELD TAB

AL14.219



2 3/4" X 2 5/8"
FLEUR-DE-LIS
WITH ANGLE

WEIGHT: 0.41 LB



ALUMINUM RINGS

Dress up you aluminum fence with welded rings.

DIE CAST

AL14.015
3"



WEIGHT: 0.15 LB

DIE CAST

AL14.017
3 1/2"



WEIGHT: 0.20 LB

DIE CAST

AL14.019
3 3/4"



WEIGHT: 0.25 LB

MADE FROM 1/2" TUBE

AL14.016
3 3/4"



WEIGHT: 0.1 LB

DIE CAST

AL14.024
5"



WEIGHT: 0.25 LB

SAND CAST

AL14.032
4"



WEIGHT: 0.23 LB

SAND CAST

AL14.033
3 7/8"



WEIGHT: 0.21 LB

DIE CAST

AL14.034



3-1/2" DOUBLE RING
WEIGHT: 0.41 LB

SAND CAST

AL14.037



3 7/8" BAMBOO
WEIGHT: 0.2 LB

SAND CAST HAMMERED

AL14.039



3 7/8"
WEIGHT: 0.10 LB

SAND CAST

AL14.041



5 5/8" DF
WEIGHT: 0.70 LB

SAND CAST

AL14.042



5 5/8" DF
WEIGHT: 0.70 LB

SAND CAST

AL14.043



5 5/8" DF
WEIGHT: 0.70 LB

SAND CAST

AL14.044



5 5/8" DF
WEIGHT: 0.70 LB

SAND CAST

AL14.045



5 5/8" DF
WEIGHT: 0.70 LB

SAND CAST

AL14.046



5 5/8" DF
WEIGHT: 0.70 LB



FORGED

AL21.990

2 1/4"

H 5 1/2"
W 1 1/2"
1.70 LB
VOLUTE



FORGED

AL21.991

2 1/4" DIXIE
LAMB TONGUE
WEIGHT: 1.67 LB





ALUMINUM END CAPS

The end cap is a minor detail but an important part of giving your railing a finished, professional look.

DIE CAST

AL15.036



FITS 2 5/8" X 1" STD RAIL

WEIGHT: 0.05 LB

DIE CAST

AL15.038



FITS 2 5/8" X 1" STD RAIL

WEIGHT: 0.05 LB

DIE CAST

AL15.039



FITS 2 5/8" X 1 1/2" DIXIE RAIL

WEIGHT: 0.05 LB

DIE CAST

AL15.046

HR10 END CAP



FITS HR-10 TOP CAP

WEIGHT: 0.05 LB

DIE CAST

AL15.046.BK

HR10 END CAP BLACK



FITS HR-10 TOP CAP

WEIGHT: 0.05 LB

DIE CAST

AL15.046.BZ

HR10 END CAP BRONZE



FITS HR-10 TOP CAP

WEIGHT: 0.05 LB

DIE CAST

AL15.046.WH

HR10 END CAP WHITE



FITS HR-10 TOP CAP

WEIGHT: 0.05 LB

DIE CAST

AL15.050

HR-1 END CAP



FITS HR-1
TOP CAP

WEIGHT: 0.05 LB

DIE CAST

AL15.050.BZ

HR-1 END CAP
BRONZE



FITS HR-1
TOP CAP

WEIGHT: 0.05

DIE CAST

AL15.050.WH

HR-1 END CAP
WHITE



FITS HR-1
TOP CAP

WEIGHT: 0.05 LB

DIE CAST

AL15.053

HR-14
END CAP



FITS HR-14
TOP CAP

WEIGHT: 0.05 LB

DIE CAST

AL15.053.BZ

HR-14
END CAP
BRONZE



FITS HR-14
TOP CAP

WEIGHT: 0.05 LB

DIE CAST

AL15.053.WH

HR-14
END CAP
WHITE



FITS HR-14
TOP CAP

WEIGHT: 0.05 LB

DIE CAST

AL19.014



FITS 1 - 1/4"
SCH40 PIPE

WEIGHT: 0.08 LB

DIE CAST

AL19.015



FITS 1 - 1/2"
SCH40 PIPE

WEIGHT: 0.08 LB

DIE CAST

AL19.016



FITS 1 - 1/2"
OD X .125
ROUND TUBE

WEIGHT: 0.08 LB

Easily connect any aluminum fence panel to a structure.

ALUMINUM WALL MOUNTS



<p>DIE CAST DOUBLE EAR</p> <p>AL13.006 1"</p>  <p>BASE 2 5/8" X 1 3/8" HEIGHT 1" WEIGHT: 0.10 LB</p>	<p>DIE CAST SINGLE EAR</p> <p>AL13.014 1 1/4"</p>  <p>BASE 2 1/4" X 1 1/8" HEIGHT 1 1/8" WEIGHT: 0.18 LB</p>	<p>DIE CAST SINGLE EAR</p> <p>AL13.020 1 1/2"</p>  <p>BASE 3 1/4" X 2 1/8" HEIGHT 1 1/2" WEIGHT: 0.20 LB</p>	<p>DIE CAST</p> <p>AL15.009 2"</p>  <p>BASE 3 5/8" X 2 1/2" HEIGHT 1 1/4" WEIGHT: 0.30 LB</p>
<p>DIE CAST</p> <p>AL15.001</p>  <p>FITS 1 1/2" X 1" RECTANGULAR TUBE WEIGHT: 0.10 LB</p>	<p>DIE CAST</p> <p>AL15.006</p>  <p>FITS 1 1/2" X 1" AR CHANNEL WEIGHT: 0.18 LB</p>	<p>DIE CAST</p> <p>AL15.002</p>  <p>FITS 2" X 1" AR CHANNEL WEIGHT: 0.12 LB</p>	<p>DIE CAST</p> <p>AL15.002.BK</p> <p>BLACK</p>  <p>FITS 2" X 1" AR CHANNEL WEIGHT: 0.12 LB</p>
<p>DIE CAST</p> <p>AL15.002.BZ</p> <p>BRONZE</p>  <p>FITS 2" X 1" AR CHANNEL WEIGHT: 0.12 LB</p>	<p>DIE CAST</p> <p>AL15.002.WH</p> <p>WHITE</p>  <p>FITS 2" X 1" AR CHANNEL WEIGHT: 0.12 LB</p>	<p>DIE CAST</p> <p>AL15.004</p>  <p>FITS 2" X 1" RECTANGULAR TUBE WEIGHT: 0.10 LB</p>	<p>DIE CAST</p> <p>AL15.004.WH WHITE</p>  <p>FITS 2" X 1" RECTANGULAR TUBE WEIGHT: 0.10 LB</p>
<p>DIE CAST</p> <p>AL15.004.BK BLACK</p>  <p>FITS 2" X 1" RECTANGULAR TUBE WEIGHT: 0.10 LB</p>	<p>DIE CAST</p> <p>AL15.004.BZ BRONZE</p>  <p>FITS 2" X 1" RECTANGULAR TUBE WEIGHT: 0.10 LB</p>	<p>DIE CAST</p> <p>AL15.021</p>  <p>FITS HR-10 SWIVEL BALL BRACKET WEIGHT: 0.18 LB</p>	<p>DIE CAST</p> <p>AL15.023</p>  <p>FITS HR-12 SWIVEL BALL BRACKET WEIGHT: 0.18 LB</p>
<p>DIE CAST</p> <p>AL15.011</p>  <p>FITS 2 5/8" X 1" TOP CAP STANDARD WEIGHT: 0.10 LB</p>	<p>DIE CAST</p> <p>AL15.013</p>  <p>FITS 2 5/8" X 1 1/2" TOP CAP STANDARD WEIGHT: 0.15 LB</p>	<p>DIE CAST</p> <p>AL15.014</p>  <p>FITS 2 5/8" X 1 1/2" TOP CAP DIXIE WEIGHT: 0.15 LB</p>	<p>DIE CAST</p> <p>AL15.027</p>  <p>FITS 2-1/4" X 7/8" CAP DIXIE WEIGHT: 0.15 LB</p>



ALUMINUM WALL MOUNTS

Easily connect any aluminum fence panel to a structure.

DIE CAST

AL15.020



FITS HR-10 MECH RAIL
WEIGHT: 0.15 LB

DIE CAST

AL15.020.BK

BLACK



FITS HR-10 MECH RAIL
WEIGHT: 0.15 LB

DIE CAST

AL15.020.BZ

BRONZE



FITS HR-10 MECH RAIL
WEIGHT: 0.15 LB

DIE CAST

AL15.020.WH

WHITE



FITS HR-10 MECH RAIL
WEIGHT: 0.15 LB

DIE CAST

AL15.022



FITS HR-12 MECH RAIL
WEIGHT: 0.10 LB

DIE CAST

AL15.022.BK

BLACK



FITS HR-12 MECH RAIL
WEIGHT: 0.10 LB

DIE CAST

AL15.022.WH

WHITE



FITS HR-12 MECH RAIL
WEIGHT: 0.10 LB

DIE CAST

AL15.022.BZ

BRONZE



FITS HR-12 MECH RAIL
WEIGHT: 0.10 LB

DIE CAST

AL15.028



FITS HR-1 MECH RAIL
WEIGHT: 0.30 LB

DIE CAST

AL15.028.BK

BLACK



FITS HR-1 MECH RAIL
WEIGHT: 0.30 LB

DIE CAST

AL15.028.BZ

BRONZE



FITS HR-1 MECH RAIL
WEIGHT: 0.30 LB

DIE CAST

AL15.028.WH

WHITE



FITS HR-1 MECH RAIL
WEIGHT: 0.30 LB

DIE CAST

AL15.029



FITS HR-14 MECH RAIL
WEIGHT: 0.22 LB

DIE CAST

AL15.029.BZ

BRONZE



FITS HR-14 MECH RAIL
WEIGHT: 0.22 LB

DIE CAST

AL15.029.WH

WHITE



FITS HR-14 MECH RAIL
WEIGHT: 0.22 LB

DIE CAST

AL15.031.MF



FITS HR-3 MECH RAIL
WEIGHT: 0.15 LB

DIE CAST

AL15.031.BZ

BRONZE



FITS HR-3 MECH RAIL
WEIGHT: 0.15 LB

DIE CAST

AL15.031.WH

WHITE



FITS HR-3 MECH RAIL
WEIGHT: 0.15 LB

DIE CAST

AL15.031.BK

BLACK



FITS HR-3 MECH RAIL
WEIGHT: 0.15 LB

Figures of animals and plants add a touch of whimsy to your design.

**ALUMINUM
PLANTS & ANIMALS**



PALM TREE

AL16.001

SF



LEFT
H 14 3/4"
W 9"
WEIGHT: 1.10 LB

PALM TREE

AL16.002

SF



RIGHT
H 14 3/4"
W 9"
WEIGHT: 1.10 LB

PALM TREE

AL16.003

SF



LEFT
H 23 1/2"
W 13 1/4"
WEIGHT: 3.80 LB

PALM TREE

AL16.004

SF



LEFT
H 23 1/2"
W 13 1/4"
WEIGHT: 3.80 LB

PALM TREE

AL16.005

DF



H 14"
W 9"
WEIGHT: 1.30 LB

PALM CORNER

AL16.007

DF



H 15 1/2"
W 14 3/4"
WEIGHT: 2.00 LB

DOLPHIN

AL16.009

FB



LEFT
H 10"
W 15 1/2"
WEIGHT: 1.50 LB

DOLPHIN

AL16.010

FB



RIGHT
H 10"
W 15 1/2"
WEIGHT: 1.50 LB

DOLPHIN

AL16.011

FB



LEFT
H 6 1/2"
W 10"
WEIGHT: 0.60 LB

DOLPHIN

AL16.012

FB



RIGHT
H 6 1/2"
W 10"
WEIGHT: 0.60 LB

MANATEE

AL16.014

LEFT



H 5 1/2"
W 17 3/4"
WEIGHT: 1.00 LB

MANATEE

AL16.015

RIGHT



H 5 1/2"
W 17 3/4"
WEIGHT: 1.00 LB

SEAHORSE

AL16.016

FB



L/R SET
H 15 3/8"
W 5 1/2"
WEIGHT: 0.90 LB

SEAHORSE

AL16.017

DF



H 21 1/2"
W 6"
WEIGHT: 3.10 LB

SAILFISH

AL16.018

DF



H 8 1/4"
W 8 3/4"
WEIGHT: 0.90 LB

TROPICAL FISH

AL16.019

DF



H 10 1/2"
W 12 3/4"
WEIGHT: 0.88 LB

FLAMINGO

AL16.023

FB



L/R SET
H 16 1/2"
W 7 1/2"
WEIGHT: 1.20 LB

FLAMINGO

AL16.024

FB



H 7"
W 16 1/4"
WEIGHT: 1.00 LB

EAGLE

AL16.025

FB



H 10"
W 27"
WEIGHT: 3.00 LB

EAGLE

AL16.026

FB



H 5 1/2"
W 19"
WEIGHT: 1.25 LB



ALUMINUM PLANTS & ANIMALS

Figures of animals and plants add a touch of whimsy to your design.

DOG BOXER

AL16.028

DF



H 11"
W 12"

WEIGHT: 2.80 LB

DOG POINTER

AL16.031

DF



H 5 3/8"
W 10 1/4"

WEIGHT: .55 LB

MARE & COLT

AL16.032

SF



H 14"
W 16 5/8"

WEIGHT: 4.50 LB

LIONS

AL16.033

SF



2 PC SET
H 11 1/4"
W 8 1/4"

WEIGHT: 4.00 LB

SAILBOAT

AL16.043



H 13 3/4"
W 12"

WEIGHT: 2.20 LB

Decorative aluminum castings for use
in fencing and gates.

ALUMINUM
DECORATIVE CASTING



BUTTERFLY SCROLL

AL20.002

3/4"



3 3/4"

WEIGHT: 0.20 LB

BUTTERFLY SCROLL

AL20.003

3/4"



H 6"

W 8 1/8"

WEIGHT: .52 LB

#1 PICKET PANEL

AL20.040

3/4"



H 16"

W 6 7/8"

WEIGHT: 0.87 LB

#1 PICKET PANEL

AL20.041

3/4"

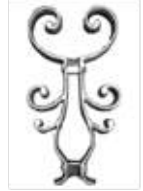

H 13"

W 7"

WEIGHT: 0.99 LB

GRAPE PICKET PANEL

AL20.061

3/4"



H 15 3/4"

W 7"

WEIGHT: 1.72 LB

ROSES PICKET PANEL

AL16.062

3/4"



H 16 1/4"

W 7"

WEIGHT: 1.62 LB

RAILING FRIEZE

AL20.101

DF



H 4"

W 30"

WEIGHT: 1.75 LB

PONTALBA

AL20.201



H 18"

W 6 3/8"

WEIGHT: 1.41 LB

C - SCROLL

AL21.021
FINS



H 3 3/4"
W 2 5/8"
1/4" X 1/2" BAR
WEIGHT: 0.13 LB

C - SCROLL

AL21.002
FINS



H 4 3/4"
W 2 15/16"
1/4" X 1/2" BAR
WEIGHT: 0.19 LB

C - SCROLL

AL21.010
PLAIN



H 4 1/2"
W 2 3/8"
1/4" X 1/2" BAR
WEIGHT: 0.15 LB

C - SCROLL

AL21.011
PLAIN



H 7 1/16"
W 3 9/16"
1/4" X 1/2" BAR
WEIGHT: 0.25 LB

C - SCROLL

AL21.001
FINS



H 5 7/8"
W 4 1/8"
1/4" X 1/2" BAR
WEIGHT: 0.13 LB

C - SCROLL

AL21.003
FINS



H 8"
W 3 7/8"
1/4" X 3/4" BAR
WEIGHT: 0.37 LB

C - SCROLL

AL21.015
FINS



H 10 1/32"
W 7 9/32"
1/4" X 3/4" BAR
WEIGHT: 0.71 LB

C - SCROLL

AL21.013
FINS



H 8 7/8"
W 6 5/16"
9/16" DIA BAR
WEIGHT: 0.73 LB

S - SCROLL

AL21.004
PLAIN



H 8 11/16"
W 4 3/4"
1/4" X 1/2" BAR
WEIGHT: 0.30 LB

S - SCROLL

AL21.005
PLAIN



H 11-7/16"
W 4-3/4"
1/4" X 1/2" BAR
WEIGHT: 0.34 LB

S - SCROLL

AL21.006
PLAIN



H 14 3/16"
W 4 3/4"
1/4" X 1/2" BAR
WEIGHT: 0.38 LB

S - SCROLL

AL21.019
FINS



H 35 7/16"
W 13 3/4"
9/16" DIA BAR
WEIGHT: 2.8 LB

DOUBLE SCROLL

AL21.049
PLAIN



H 28 3/8"
W 9 1/4"
1/4" X 3/4" BAR
WEIGHT: 1.8 LB

DOUBLE SCROLL

AL21.054
PLAIN



H 35 7/16"
W 13 9/16"
9/16" DIA BAR
WEIGHT: 4.0 LB

VOLUTE

AL16.990



2 1/4" DIXIE
WEIGHT: 1.67 LB

LAMB TONGUE

AL21.991



2 1/4" DIXIE
WEIGHT: 1.67 LB

BASKET

AL21.101
3/16"



H 5 1/2"
W 2 3/8"
WEIGHT: 0.21 LB

BASKET

AL21.103
1"



H 7 1/16"
W 3 3/4"
WEIGHT: 0.92 LB

BALUSTER

AL16.208
CENTER TWIST



5/8" SQ
H 39 1/2"
WEIGHT: 1.5 LB

BALUSTER

AL16.209
DOUBLE TWIST



5/8" SQ
H 39 1/2"
WEIGHT: 1.5 LB

Metal scrolls for wall art, railing panels,
and decorative accents in aluminum

ALUMINUM FORGE ITEMS

LEAF

AL21.181
LEFT



H 4 5/16"
W 1 9/16"
WEIGHT: 0.05 LB

LEAF

AL21.182
RIGHT



H 4 5/16"
W 1 9/16"
WEIGHT: 0.05 LB

LEAF

AL21.183
LEFT



H 2 3/8"
W 2 3/4"
WEIGHT: 0.04 LB

LEAF

AL21.184
RIGHT



H 2 3/8"
W 2 3/4"
WEIGHT: 0.04 LB

ROSETTE

AL21.430



10 1/2" DIA
1/4" X 1/2" BAR
WEIGHT: 0.80 LB



GRIP RAIL

Accessories to simplify your job.

90 DEGREE ELBOW

AL19.120
1 1/4" SCH 40

2.5" C.L.R
6063 ALUM
WEIGHT: 0.26 LB



180 DEGREE RETURN

AL19.125
1 1/4" SCH 40

12" C.L.R
WITH TANGENTS
6063 ALUM
WEIGHT: 1.87 LB



90 DEGREE ELBOW

AL19.127
1 1/2" SCH 40

2.5" C.L.R
6063 ALUM
WEIGHT: 0.31 LB



90 DEGREE ELBOW

AL19.119
1 1/2" OD TUBE .125" W

3" C.L.R
6061 ALUM
WEIGHT: 0.23 LB



90 DEGREE ELBOW

AL19.134
2" OD TUBE .125" W

3" C.L.R
6061 ALUM
WEIGHT: 0.33 LB



DIE CAST ALUM

AL19.001
1 1/4" SCH 40

PIPE MOUNT
BASE=3.7" DIA
WEIGHT: 0.06 LB



DIE CAST ALUM

AL19.002
1 1/2" SCH 40

PIPE MOUNT
BASE=3.94" DIA
WEIGHT: 0.06 LB

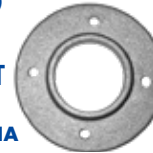

DIE CAST ALUM

AL19.003
1 1/2" OD

TUBE MOUNT
BASE=3.5" DIA
WEIGHT: 0.05 LB



DIE CAST ALUM

AL19.014
1 1/4" SCH 40

END CAP

WEIGHT: 0.02 LB



DIE CAST ALUM

AL19.015
1 1/2" SCH 40

END CAP

WEIGHT: 0.02 LB



DIE CAST ALUM

AL19.016
1 1/2" OD

TUBE END CAP

WEIGHT: 0.02 LB



DOMED END CAP

AL19.176
FITS 2" OD TUBE

3003 ALUM

WEIGHT: 0.9 LB



SAND CAST ALUM

AL19.021
2 1/2" PROJECTION

GRIP RAIL BRACKET

WEIGHT: 0.25 LB



PLASTIC

PL16.026.BK
1 1/4" SCH 40

END CAP BLACK

WEIGHT: 0.01 LB



PLASTIC

PL16.026.WH
1 1/4" SCH 40

END CAP WHITE

WEIGHT: 0.01 LB



PLASTIC

PL16.026.BZ
1 1/4" SCH 40

END CAP BRONZE

WEIGHT: 0.01 LB



PLASTIC

PL16.027.BK
1 1/2" SCH 40

END CAP BLACK

WEIGHT: 0.01 LB



PLASTIC

PL16.027.WH
1 1/2" SCH 40

END CAP WHITE

WEIGHT: 0.01 LB



PLASTIC

PL16.025.BK
1 1/2" OD X .125" W

TUBE END CAP BLACK

WEIGHT: 0.01 LB



PLASTIC

PL16.025.WH
1 1/2" OD X .125" W

TUBE END CAP WHITE

WEIGHT: 0.01 LB



AMID

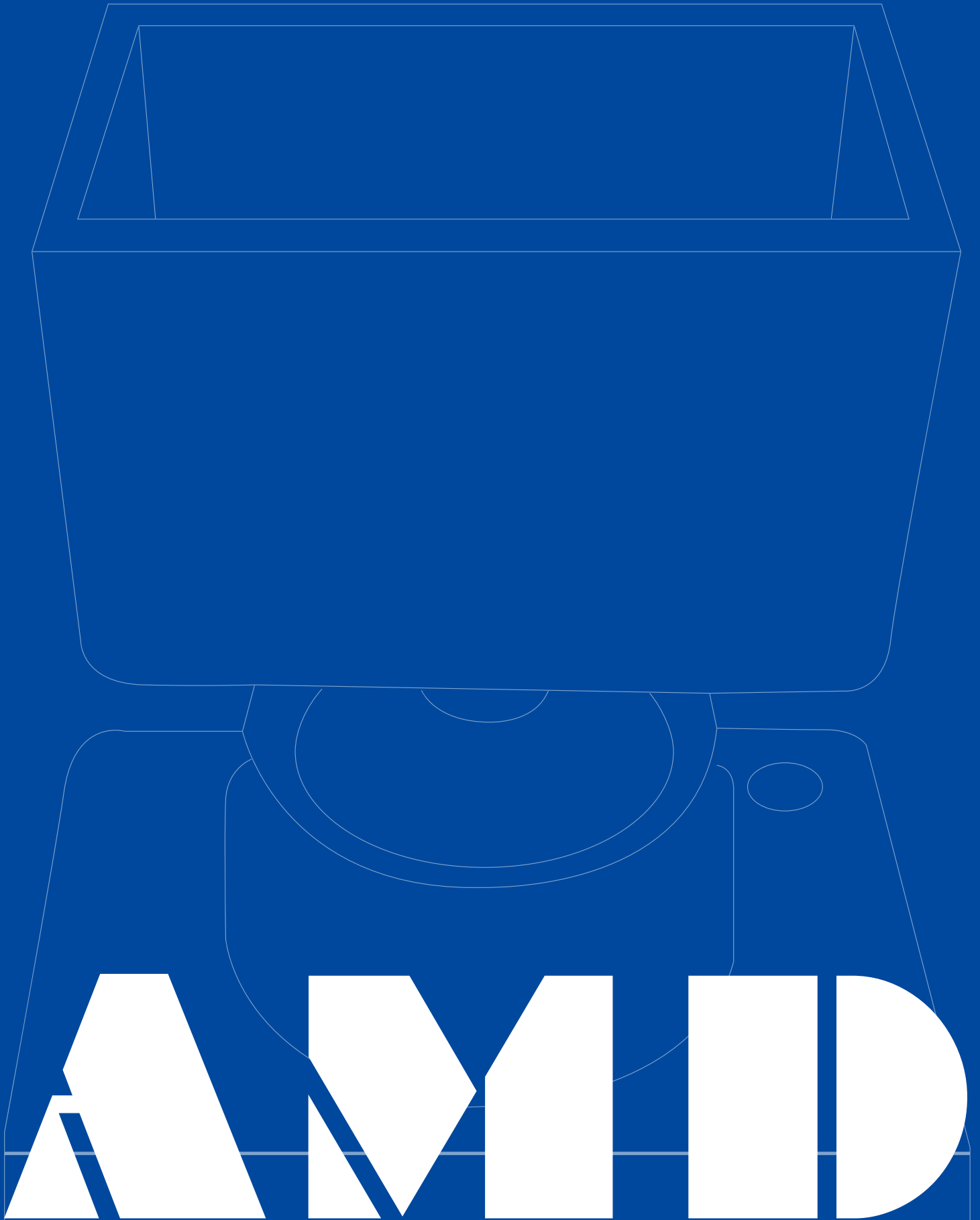

WWW.FITTINGSPLUS.COM